

# 4S-2M Air System Schematic

Tandem Axle Tag Trailers

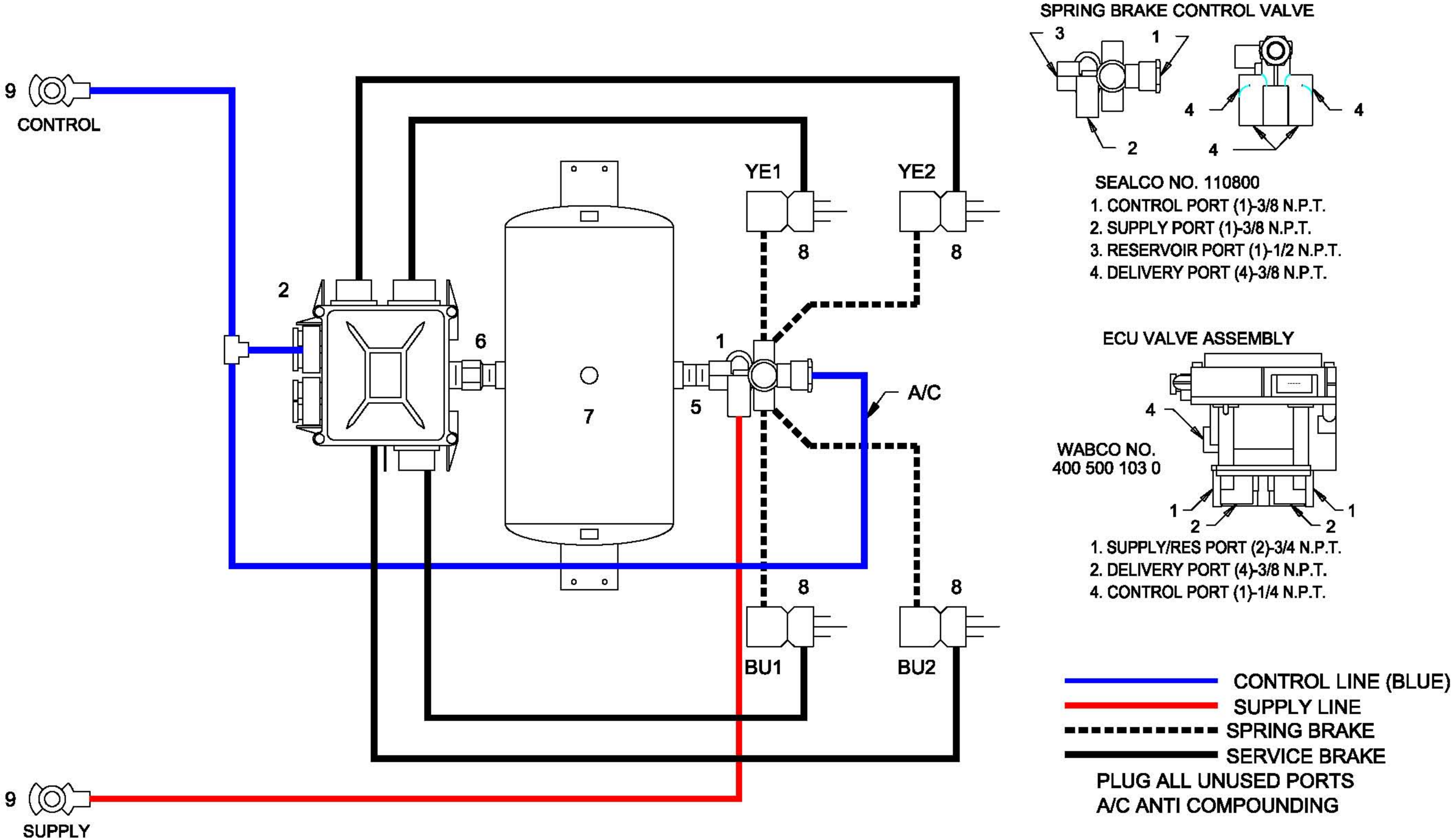

Anti-Compounding Note: When the spring brakes are applied, the anti-compounding port on the Spring Brake Control Valve disables the blue control line air by venting it to atmosphere. This prevents the compounding effect of applying service brakes when the spring brakes are enabled. Control air will be heard during this venting.