

# 4S-3M Air System Schematic for Tri-Axle Tag - Model 25XPT

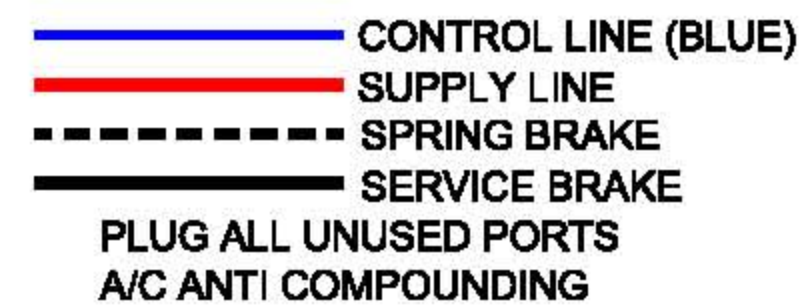

Item	Description
1	Spring Brake Valve
2	ECU ABS Valve
3	ABS Relay Valve
4	Wheel Sensors
5	3/4" x 3/4" Nipple
6	3/4" x 1/2" Nipple
7	2850 Culin Air Tank
8	Air Brake Chambers
9	Glad-hands
10	Sensor Extension Cable
11	Mounting Tee

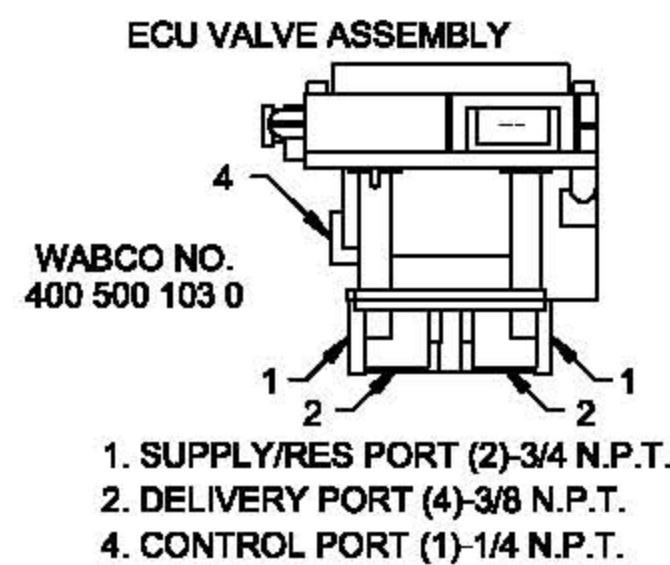
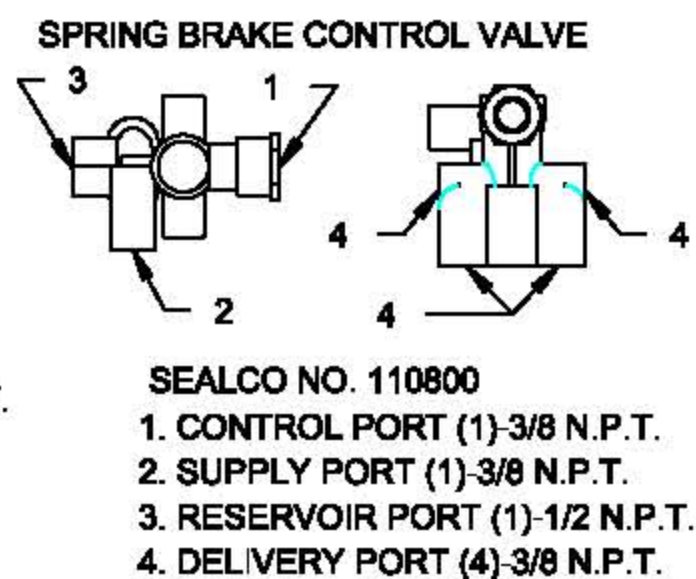
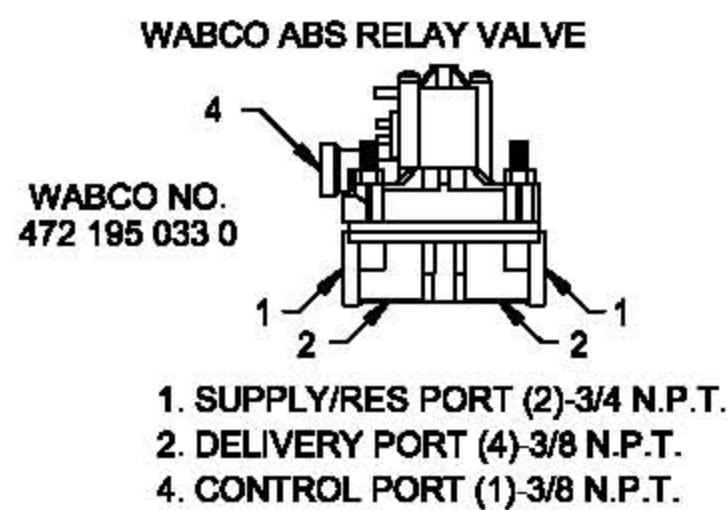
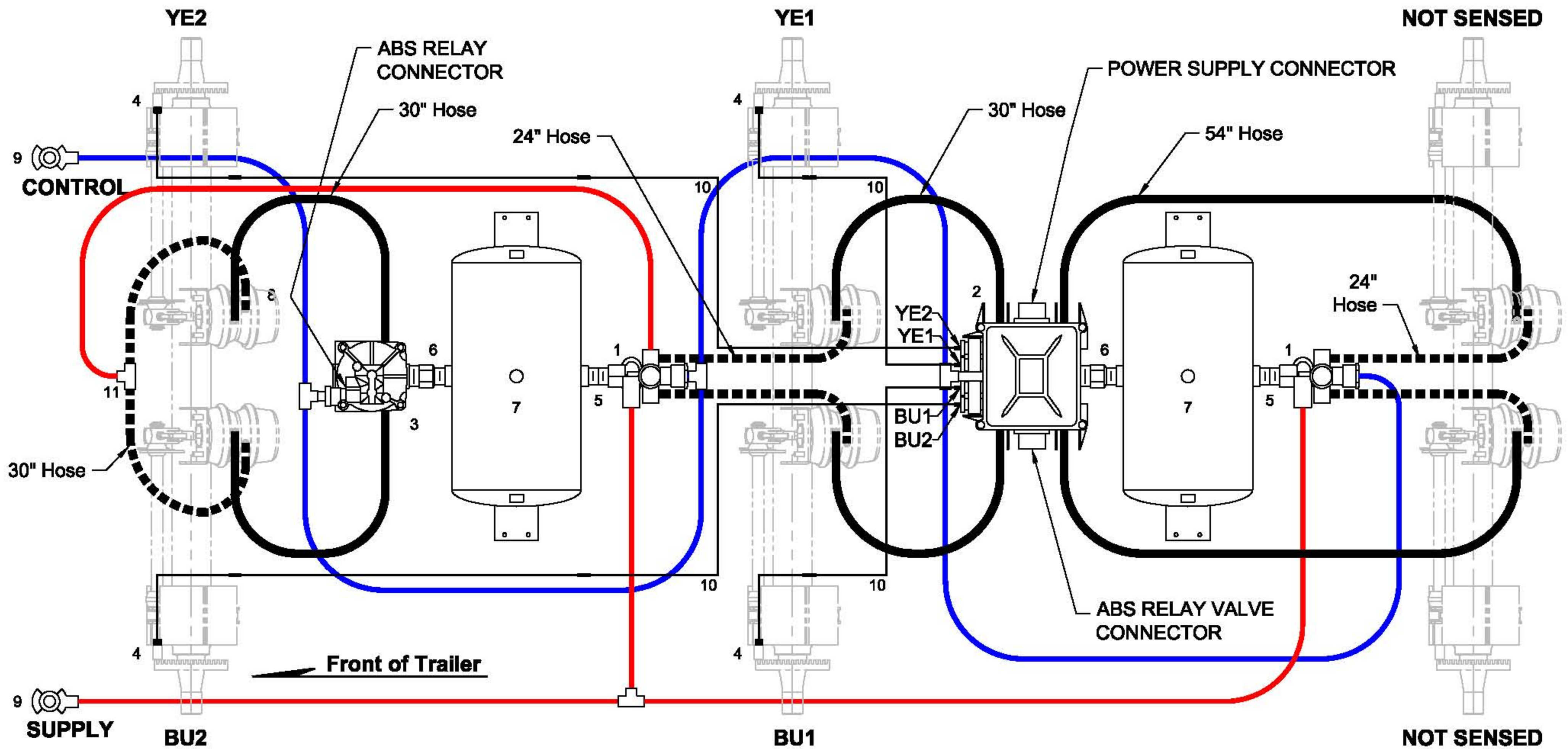

General Engines Co., Inc., 14800 Highway 27, Lake Wales, Florida, USA, 33859, 1-800-287-9185

This drawing and specifications are the property of General Engines Co., Inc. All Eager Beaver Trailers shall not be reproduced, copied or used in any fashion without express written permission. Also, General Engines Co., Inc. reserves the right to change designs, specification or materials without notice and without incurring any obligation to such changes.

**Note:** ALL air lines and hoses must be properly routed and secured, so to prevent contact with any surfaces or each other.